

PARÇA KODU PART CODE	PARÇA ADI PART NAME	s ÖLÇÜSÜ (KALINLIK) s MEASURE (THICKNESS)	Malzeme Material	Kaplama / Coating		
				SN	AG	Nİ
TŞ 2448 DP	KARE SİGORTA TERMİNAL Ø2.8 =DP=	-----	(CuZn30) Pirinç / Brass	-	-	-
TŞ 2448 RP	KARE SİGORTA TERMİNAL Ø2.8 =RP=	-----	(CuZn30) Pirinç / Brass	-	-	-
TŞ 2448 RPK	KARE SİGORTA TERMİNAL Ø2.8 =RPK=	-----	(CuZn30) Pirinç / Brass	+	-	-

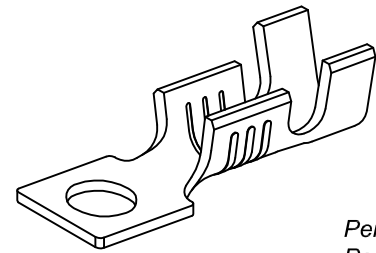

Perspektif
Perspective

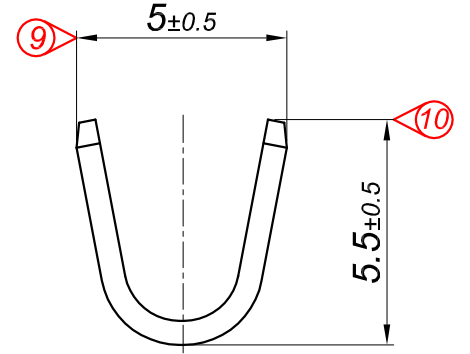
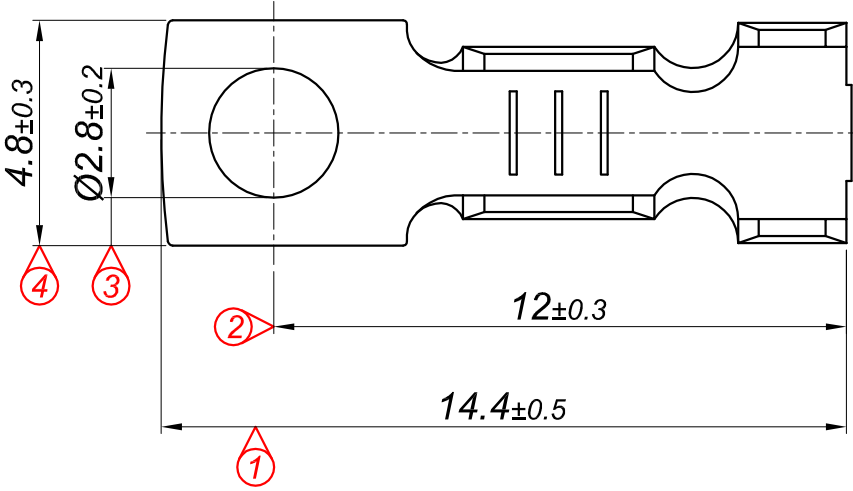
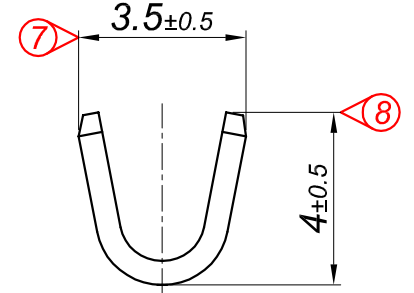
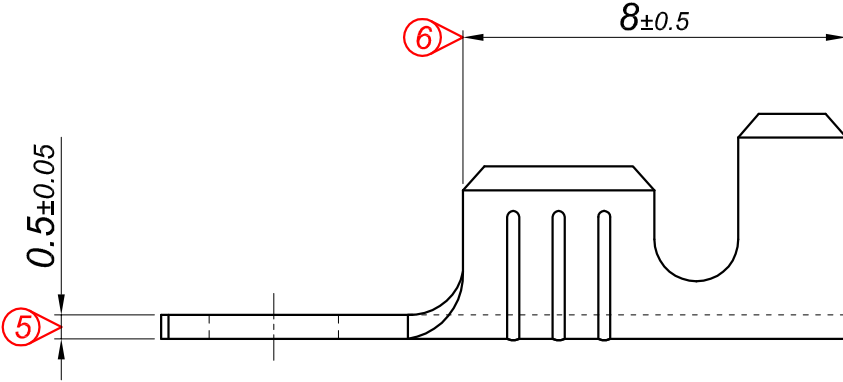
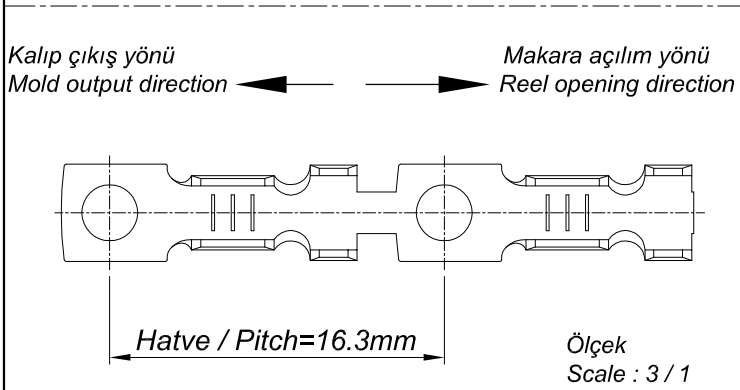

Kablo Kesiti
Wire Section : 1 - 2.50 mm²

Resim üzerinden ölçü almayınız
do not measure on drawing

Tarih / Date	31.07.2013	İmza / Signature	Ölçek / Scale		
Çizen / Desing	M. Yağcı		5 / 1	No	
Onay / Approval	S. Gölçük				Değişiklik / Revision
					Tarih/Date
	Parça Adı: Part Name	KARE SİGORTA TERMİNAL Ø2.8			Parça Kodu: Part Code
					TŞ 2448